

VB 3D - 2000

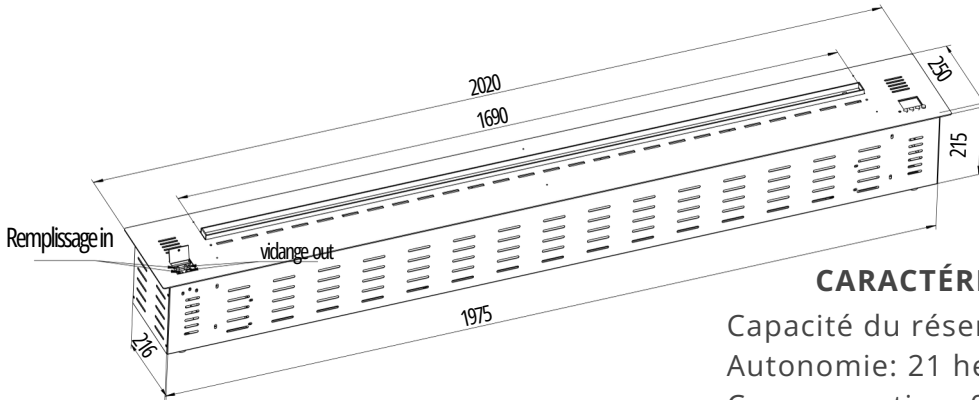

CARACTÉRISTIQUES TECHNIQUES

Capacité du réservoir : 8.7 L
 Autonomie: 21 heures
 Consommation: 0.4L/h
 Dimensions : 202 x 25 x 22 cm (L x l x H)
 Poids : 62 kg

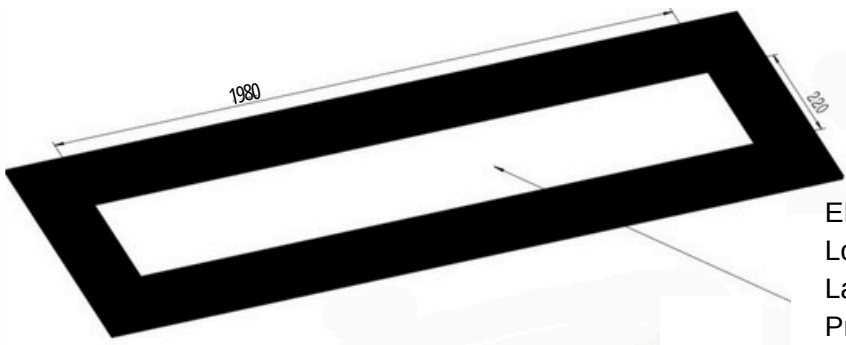

ENCASTREMENT
 Longueur: 1980 mm
 Largeur: 220 mm
 Profondeur: 230 mm



Télécommande

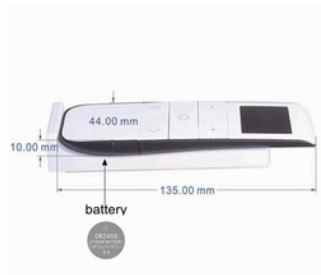

Écran et commandes sur le bloc

Création Entrée d'air

