

**VB 3D - 2300**

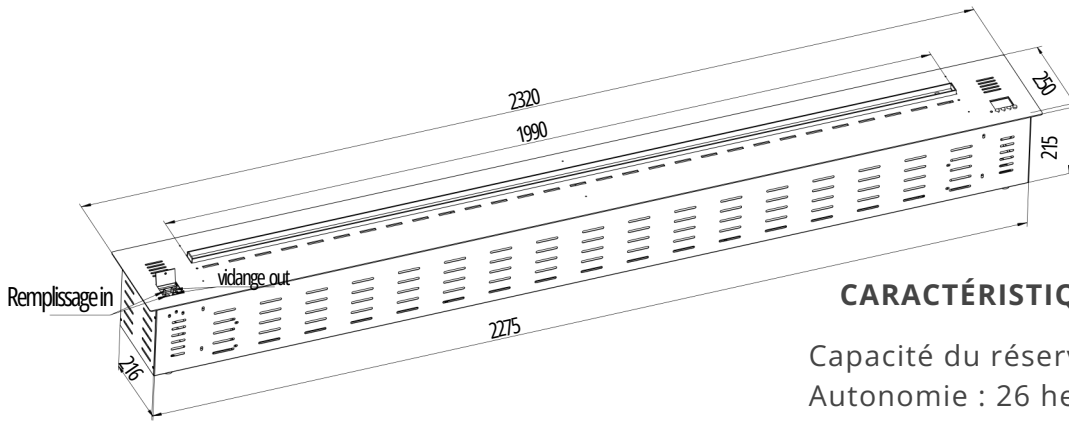

**CARACTÉRISTIQUES TECHNIQUES**

Capacité du réservoir : 10.7 L  
 Autonomie : 26 heures  
 Consommation : 0.4L/h  
 Dimensions : 232 x 25 x 22 cm (L x l x H)  
 Poids : 72 kg

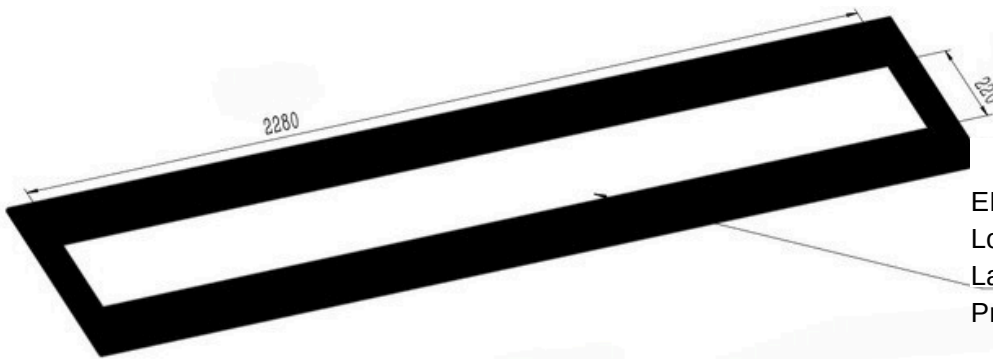

**ENCASTREMENT**  
 Longueur: 2280 mm  
 Largeur: 220 mm  
 Profondeur: 230 mm



Télécommande

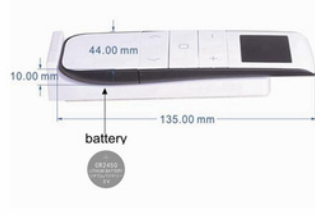

Écran et commandes sur le bloc

**Création Entrée d'air**

